

American Polysteel PS 4890-1L Scale 1.5"=12.0"

FRONT ELEV,

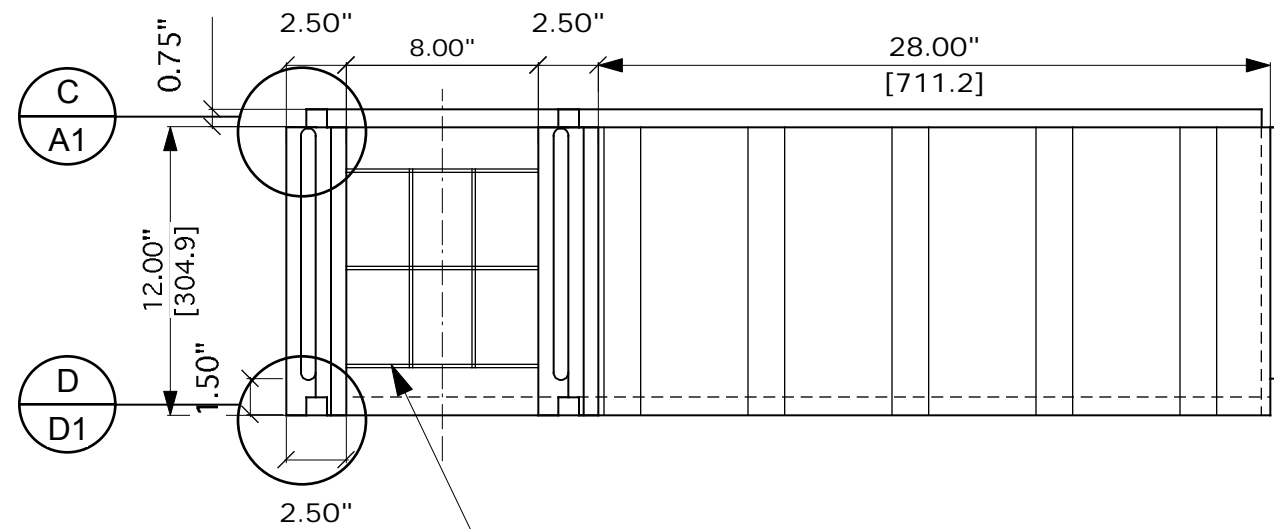

STEEL FURRING TIE
SEE DETAIL SHEET D2

SECTION A

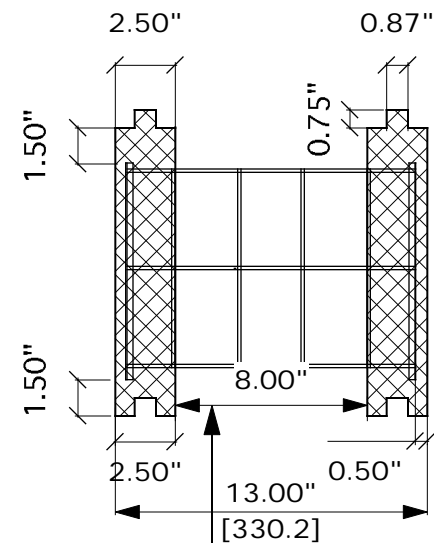

NOTE:
8" (203.2 mm) MINIMUM CAVITY

END ELEV,

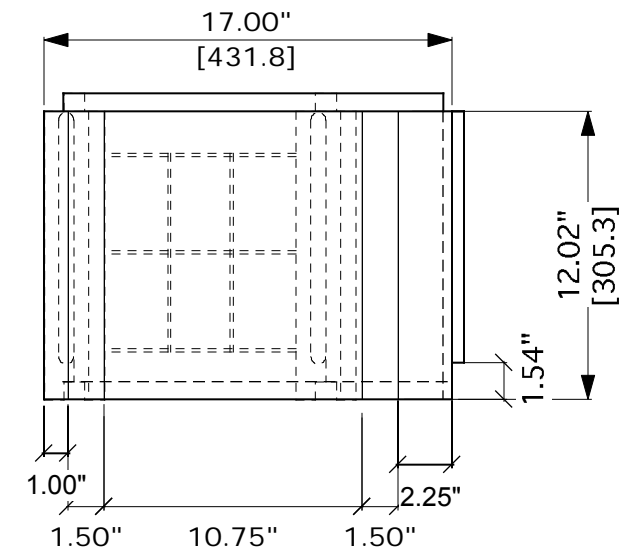

PLAN - LEFT-HAND CORNER

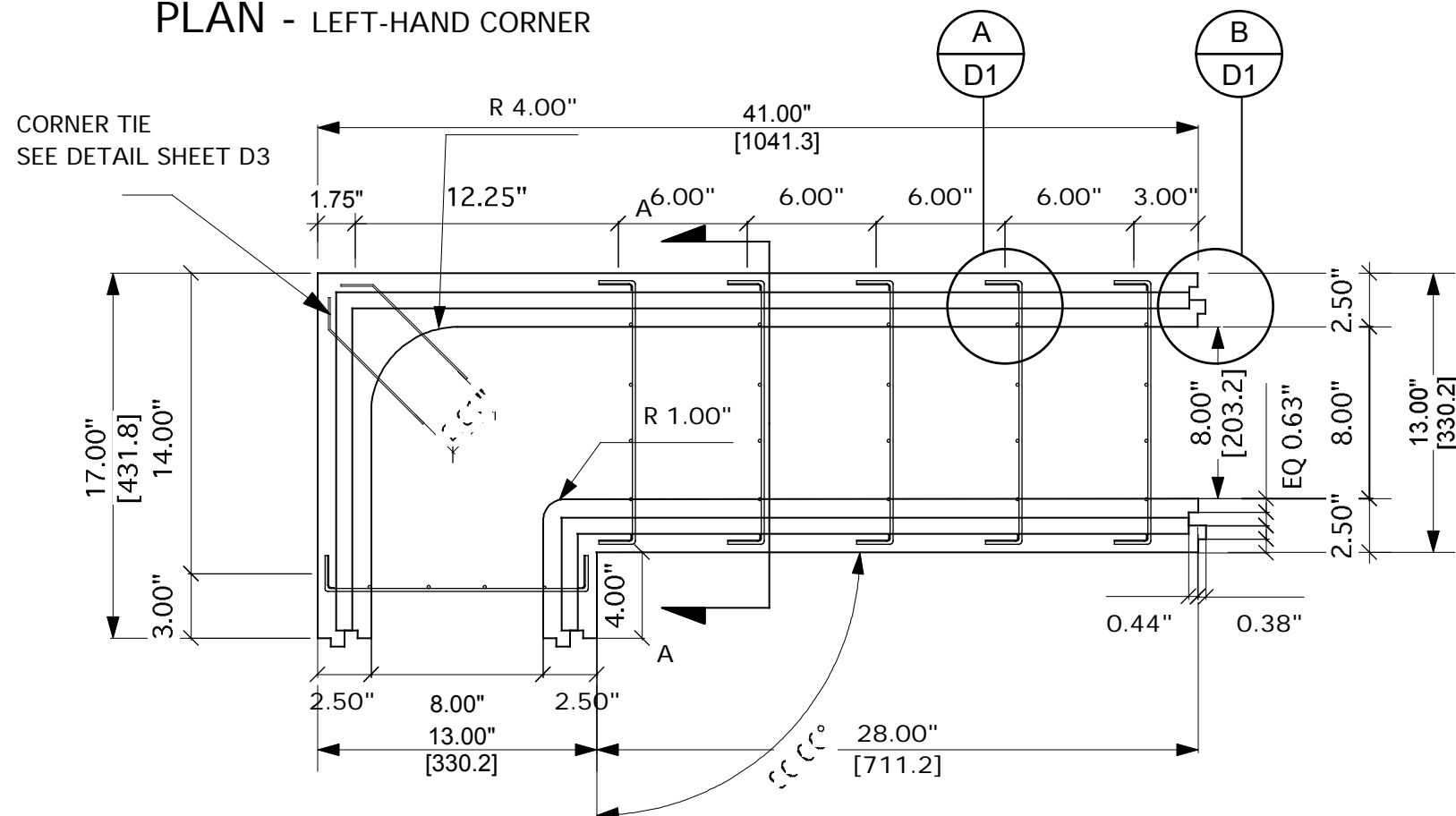

CORNER TIE
SEE DETAIL SHEET D3

SKETCH OF END TONGUE & GROOVE

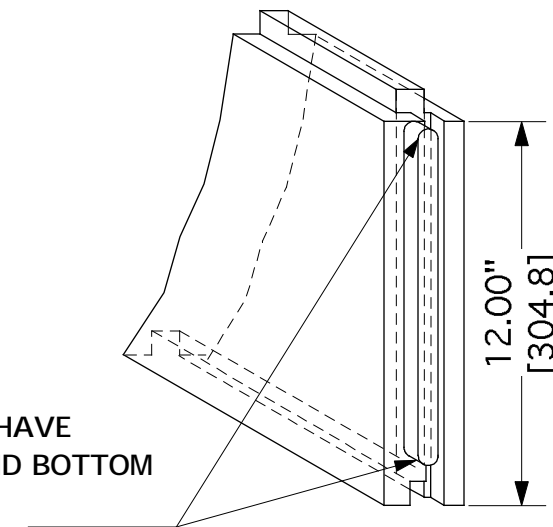

EACH TONGUE TO HAVE
RADIUS AT TOP AND BOTTOM

NOTE;
SEE POLYSTEEL DETAIL SHEETS (D1-D3) FOR
ADDITIONAL INFORMATION

American Polysteel PS 4890-1L		
SCALE: 1.5"=12.0"	APPROVED BY:	DRAWN BY: AH
DATE: Mar 2002		REVISED:
Copyright 2002		DRAWING NUMBER:
American Polysteel 1-800-977-3676		PS 4890-1L